

Gradient modeling of memristive circuits

Fulvio Forni, Rodolphe Sepulchre

KU Leuven, September 2025

Gradient modeling of memristive circuits

Part 1: Motivation

Part 2: Gradient resistive and memristive elements

Part 3: linear RC and mem-RC circuits

Part 4: On memcapacitance and excitable robotics...

Motivation 1: the Hodgkin-Huxley's neuron (1952)

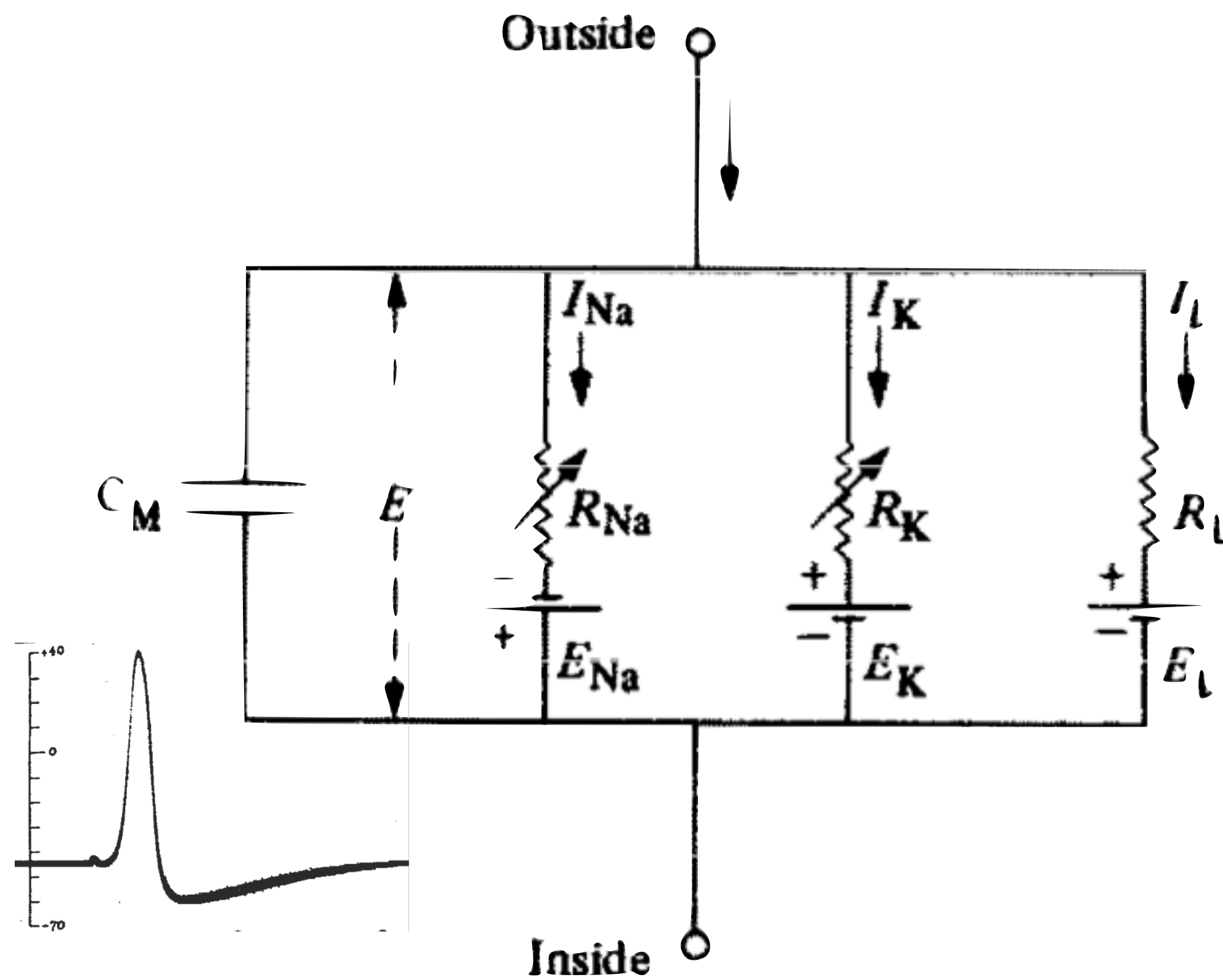

$$I = C_M \frac{dV}{dt} + I_{Na} + I_K + I_l.$$

$$I_{Na} = g_{Na}(V - V_{Na}),$$

$$I_K = g_K(V - V_K),$$

$$I_l = \bar{g}_l(V - V_l),$$

Motivation 1: the Hodgkin-Huxley's neuron (1952)

$$I = C_M \frac{dV}{dt} + g_K(V - V_K) + g_{Na}(V - V_{Na}) + \bar{g}_l(V - V_l),$$

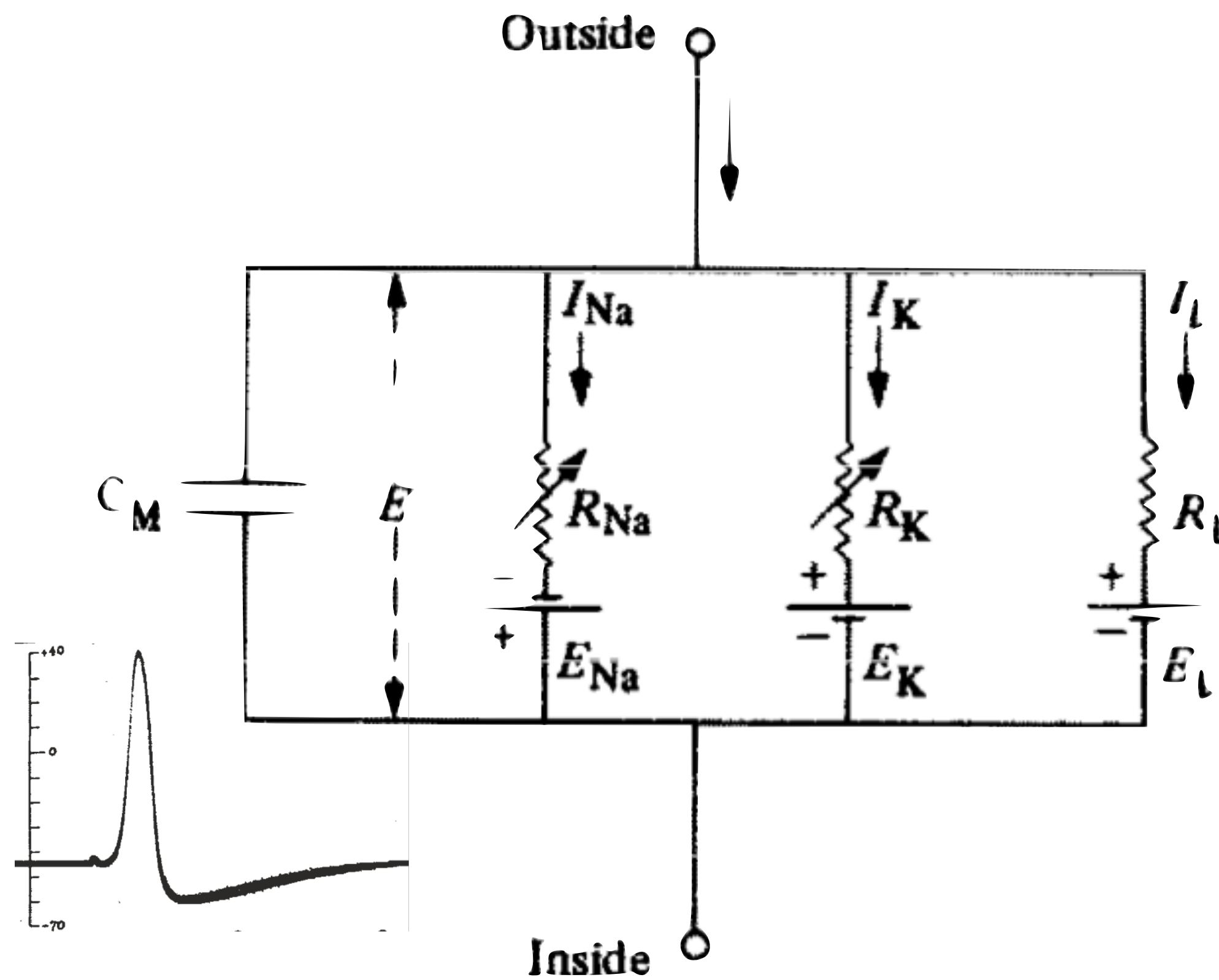

Motivation 1: the Hodgkin-Huxley's neuron (1952)

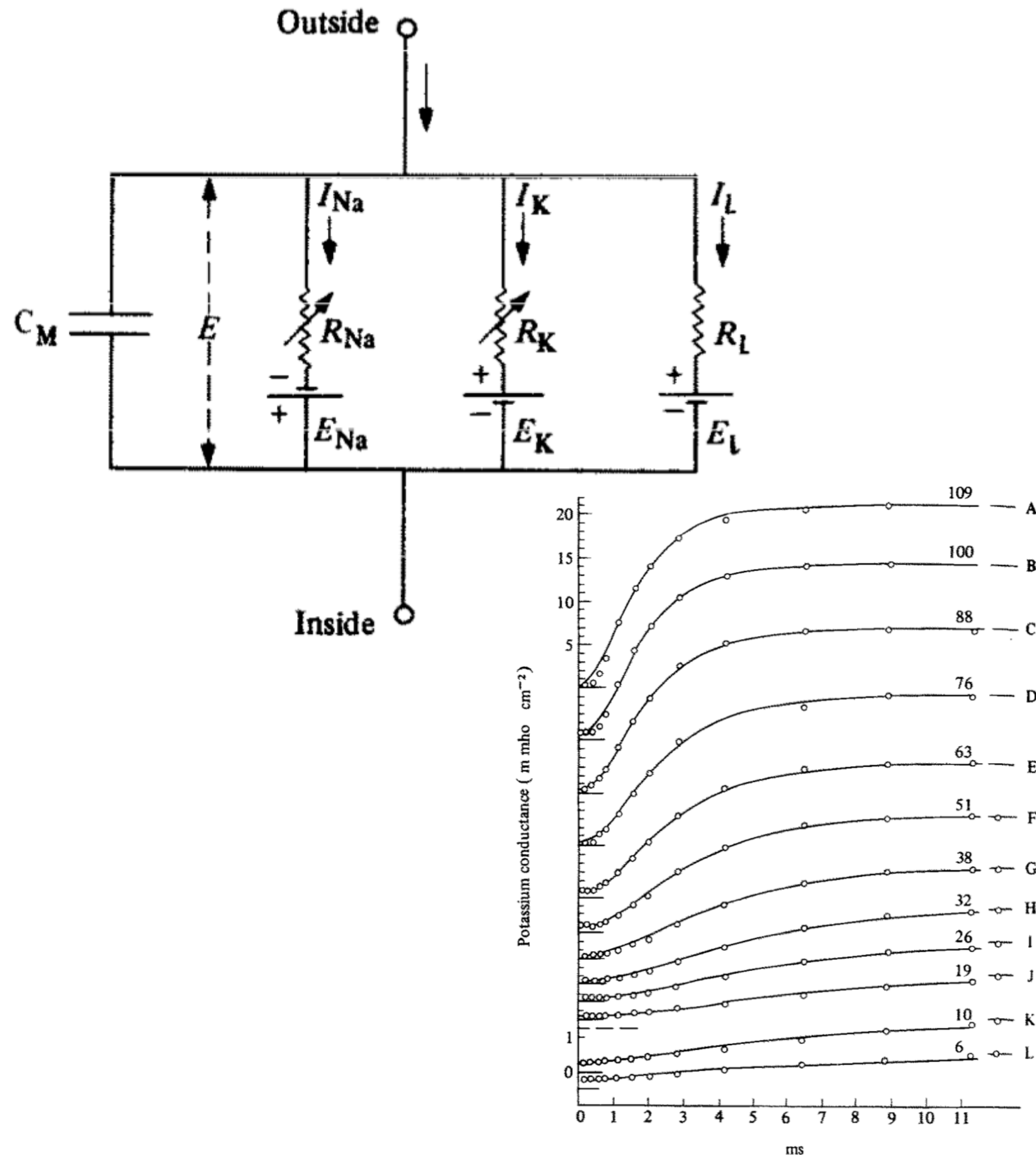

$$I = C_M \frac{dV}{dt} + \bar{g}_K n^4 (V - V_K) + \bar{g}_{Na} m^3 h (V - V_{Na}) + \bar{g}_l (V - V_l),$$

$$\frac{dh}{dt} = \alpha_h (1 - h) - \beta_h h,$$

$$\frac{dn}{dt} = \alpha_n (1 - n) - \beta_n n,$$

$$\frac{dm}{dt} = \alpha_m (1 - m) - \beta_m m,$$

$$\alpha_n = 0.01 (V + 10) / \left(\exp \frac{V + 10}{10} - 1 \right),$$

$$\beta_n = 0.125 \exp(V/80),$$

$$\alpha_h = 0.07 \exp(V/20),$$

$$\beta_h = 1 / \left(\exp \frac{V + 30}{10} + 1 \right),$$

$$\alpha_m = 0.1 (V + 25) / \left(\exp \frac{V + 25}{10} - 1 \right),$$

$$\beta_m = 4 \exp(V/18),$$

Motivation 2: Chua's memristive system (1976)

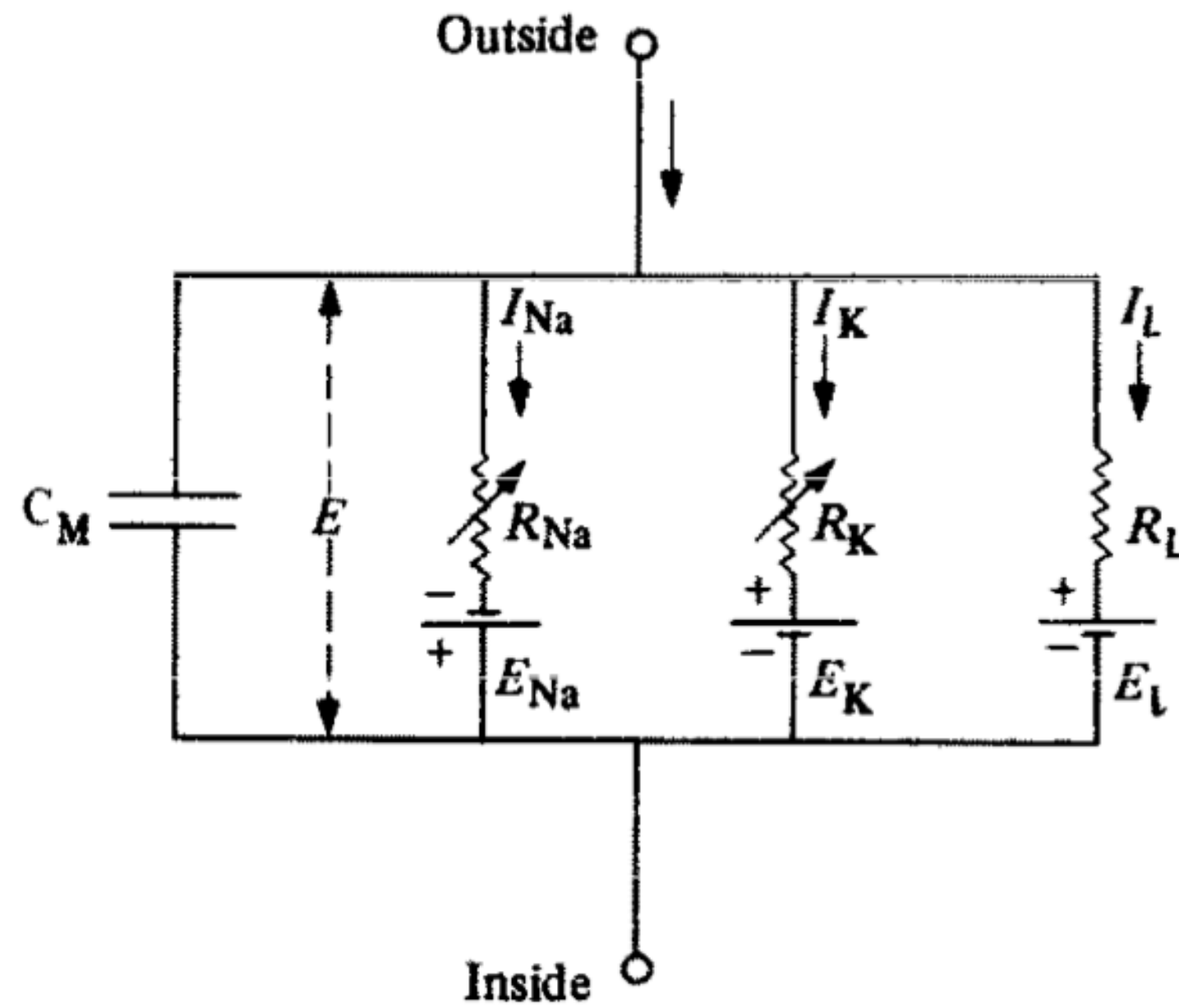

$$\dot{x} = f(x, u, t)$$

$$y = g(x, u, t)u$$

$$\dot{x} = f(x, i, t)$$

$$v = R(x, i, t)i$$

If $R(x, i) \geq 0$, then

Passive

$$\int_{t_0}^t v(\tau) i(\tau) d\tau = \int_{t_0}^t R(x(\tau), i(\tau)) i^2(\tau) d\tau \geq 0,$$

No energy discharge property

$$v(t)i(t) \geq 0 \quad \text{for all } t$$

Motivation 3: state functions of a memristor? (Chua 1971, Jeltsema-Scherpen 2009)

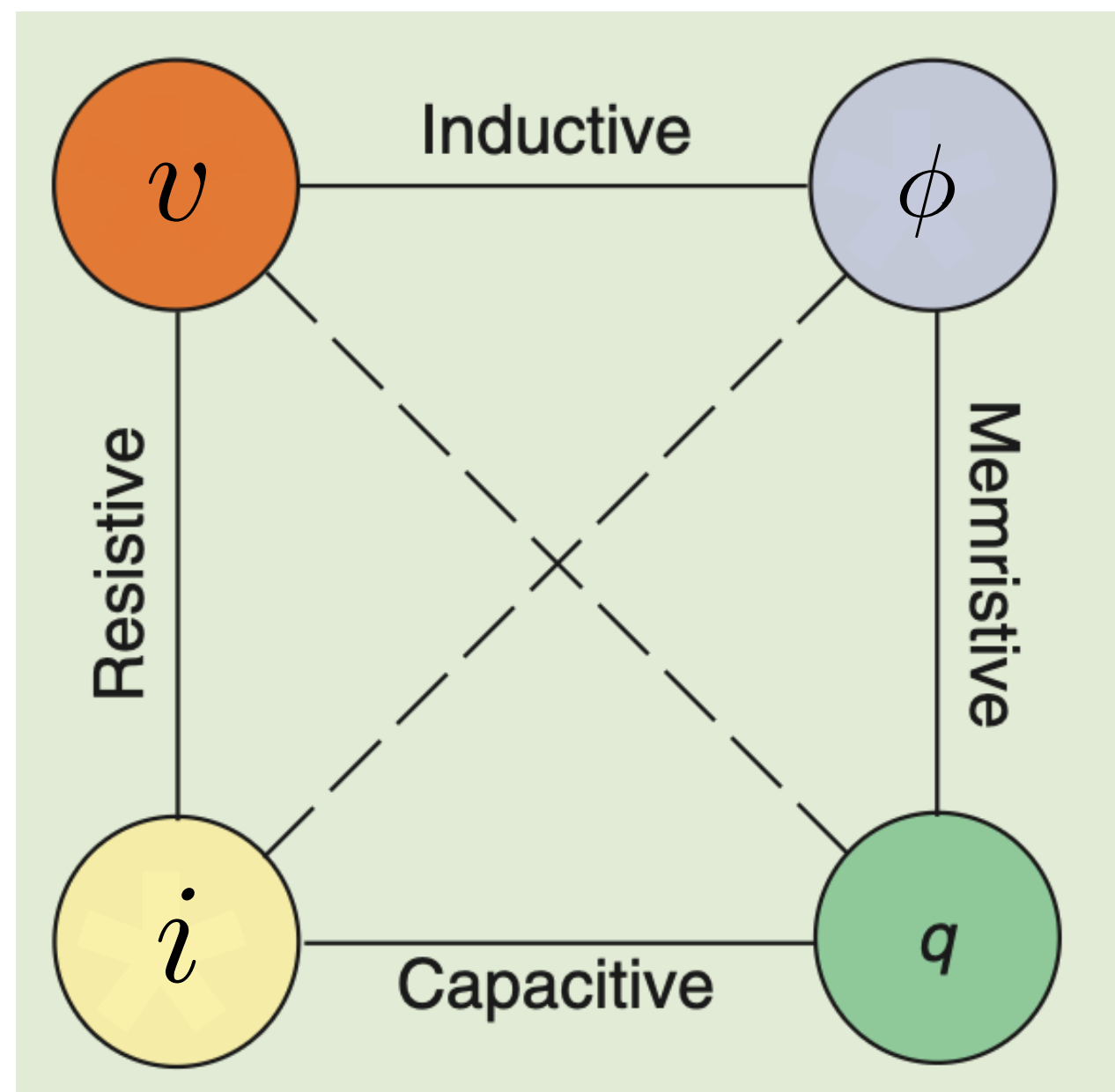

$$\phi = m(q)$$

$$v = \frac{d}{dt} \phi$$

$$i = \frac{d}{dt} q$$

$$v = M(q)i = M \left(\int i \right) i$$

$$M(q) := \frac{\partial m(q)}{\partial q}$$

$$v = M(x)i \quad \dot{x} = i$$

Motivation 3: state functions of a memristor? (Chua 1971, Jeltsema-Scherpen 2009)

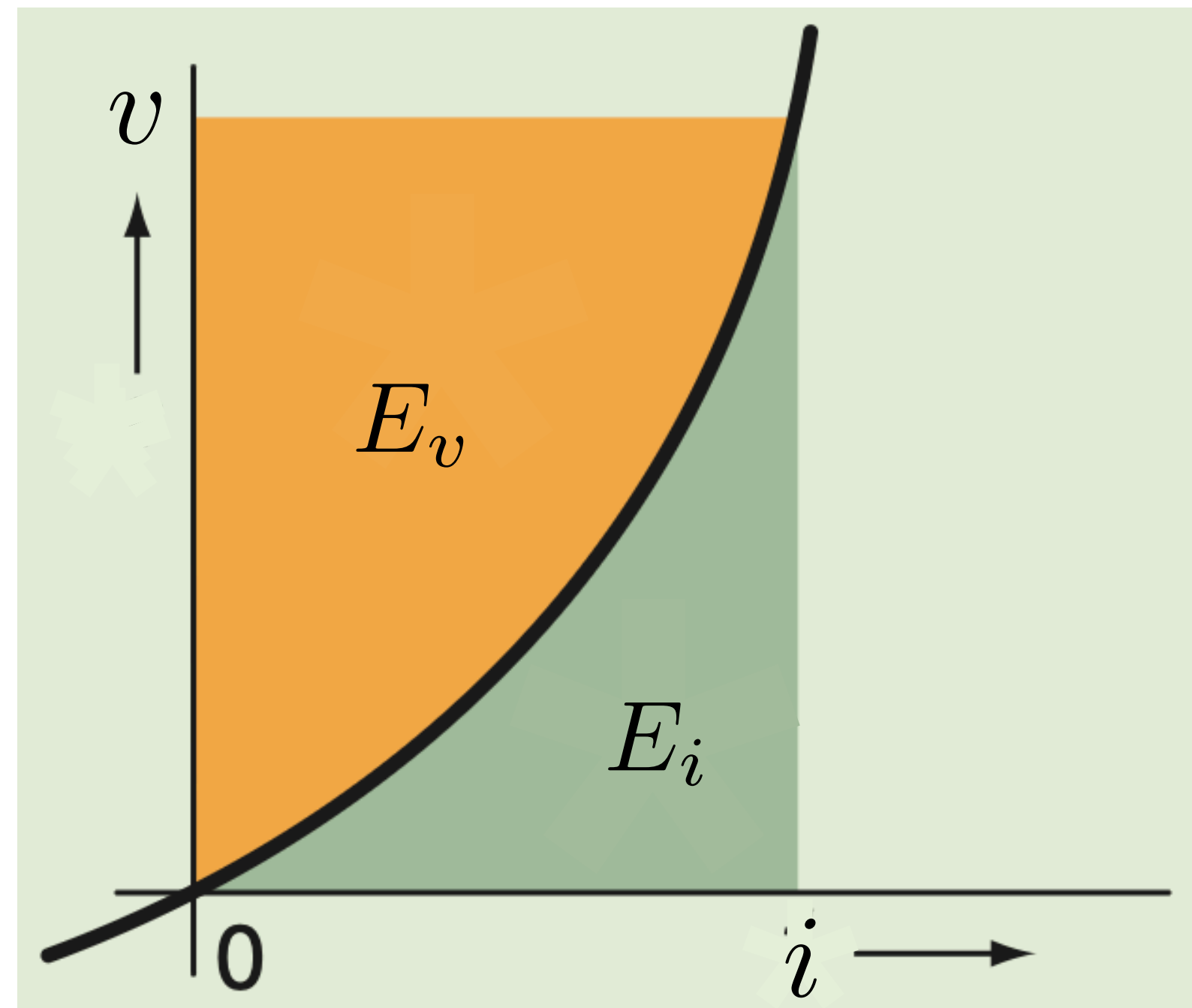

Content and co-content

$$i = g(v) = \frac{\partial}{\partial v} E_v \quad E_v = \int_0^v i dv = \int_0^v g(v) dv$$

$$v = r(i) = \frac{\partial}{\partial i} E_i \quad E_i = \int_0^i v di = \int_0^i r(i) di$$

$$E_i = E_v = \frac{1}{2} Ri^2$$

Part 1: Motivation

Instantaneous i-v relation
that depends on the past

$$\begin{aligned}\dot{x} &= f(x, u, t) \\ y &= g(x, u, t)u\end{aligned}$$

Physics of ODEs with 'internal' variables? Why?

Physics fundamentals: passivity, power
dissipation, content and co-content

$$\int_{t_0}^t v(\tau) i(\tau) d\tau \geq 0, \quad v(t)i(t) \geq 0$$

state functions of a memristor?

Hodgkin-Huxley neurons (mem-circuit)

Gradient modeling of memristive circuits

Part 1: Motivation

Part 2: Gradient resistive and memristive elements

Part 3: linear RC and mem-RC circuits

Part 4: On memcapacitance and excitable robotics...

Memristive element

Operator-theoretic view



$$\mathbf{i}(t) = \mathbf{g}(\mathbf{v})(t) \mathbf{v}(t),$$

$$\mathbf{v} \in \mathcal{L}_2(-\infty, T]$$

$$i = g(\mathbf{v}) v.$$

Instantaneous but past-dependent i-v relation

Assumption 1: [Fading memory]

Input signals that differ in the remote past have similar current outputs

Assumption 2: [Energy dissipation]

$$\mathbf{g}(\mathbf{v})(t) \geq \varepsilon > 0,$$

$$\langle \mathbf{i}, \mathbf{v} \rangle = \int_{-\infty}^T \mathbf{i}(t) \mathbf{v}(t) dt = \int_{-\infty}^T \mathbf{v}(t) \mathbf{g}(\mathbf{v})(t) \mathbf{v}(t) dt = \langle \mathbf{v}, \mathbf{v} \rangle_{\mathbf{g}} \geq 0$$

Dissipated energy is the Riemannian metric

From a geometric perspective, if we endow $\mathcal{L}_{2(-\infty, T]}$ with the structure of a Riemannian manifold $(\mathcal{L}_{2(-\infty, T]}, \mathbf{g})$, the dissipated energy of a memristive element corresponds to the quadratic norm $\|\mathbf{v}\|_g^2$ associated to the weighted inner product

$$\langle \mathbf{v}_1, \mathbf{v}_2 \rangle_g = \int_{-\infty}^T \mathbf{v}_1(t) \mathbf{g}(\mathbf{v})(t) \mathbf{v}_2(t) dt \geq 0,$$

where \mathbf{v}_1 and $\mathbf{v}_2 \in T_{\mathbf{v}}\mathcal{L}_{2(-\infty, T]}$ are generic tangent vectors. This interpretation of the memconductance as a Riemannian metric is the basis of the gradient modelling in the next section.

Linear resistor

$$i = gv$$

Dissipated energy

$$\mathcal{D}(v) := \langle i, v \rangle = gv^2 = \langle v, v \rangle_g$$

Co-content

$$\mathcal{E}(\bar{v}) := \int_0^{\bar{v}} \langle i, dv \rangle = \int_0^{\bar{v}} gv dv = \frac{1}{2} \langle \bar{v}, \bar{v} \rangle_g$$

The co-content determines the resistive relationship

$$\langle \text{grad } \mathcal{E}(v), v \rangle = D_v \mathcal{E}(v) = gv^2$$

$$i = \text{grad } \mathcal{E}(v) = gv.$$

Nonlinear resistor

$$i = g(v)v$$

Dissipated energy

$$\mathcal{D}(v) := \langle i, v \rangle = g(v)v^2 = \langle v, v \rangle_g$$

Co-content

$$\mathcal{E}(\bar{v}) := \int_0^{\bar{v}} \langle i, dv \rangle = \int_0^{\bar{v}} g(v)v dv \neq \frac{1}{2} \langle \bar{v}, \bar{v} \rangle_g$$



The co-content determines the resistive relationship

$$\langle \text{grad } \mathcal{E}(v), v \rangle = D_v \mathcal{E}(v) = g(v)v^2$$

$$i = \text{grad } \mathcal{E}(v)$$

Nonlinear resistor

The linear equivalent between dissipation and co-content is recovered by taking the voltage space as a Riemannian manifold with metric $1/g$

$$i = g(v)v$$

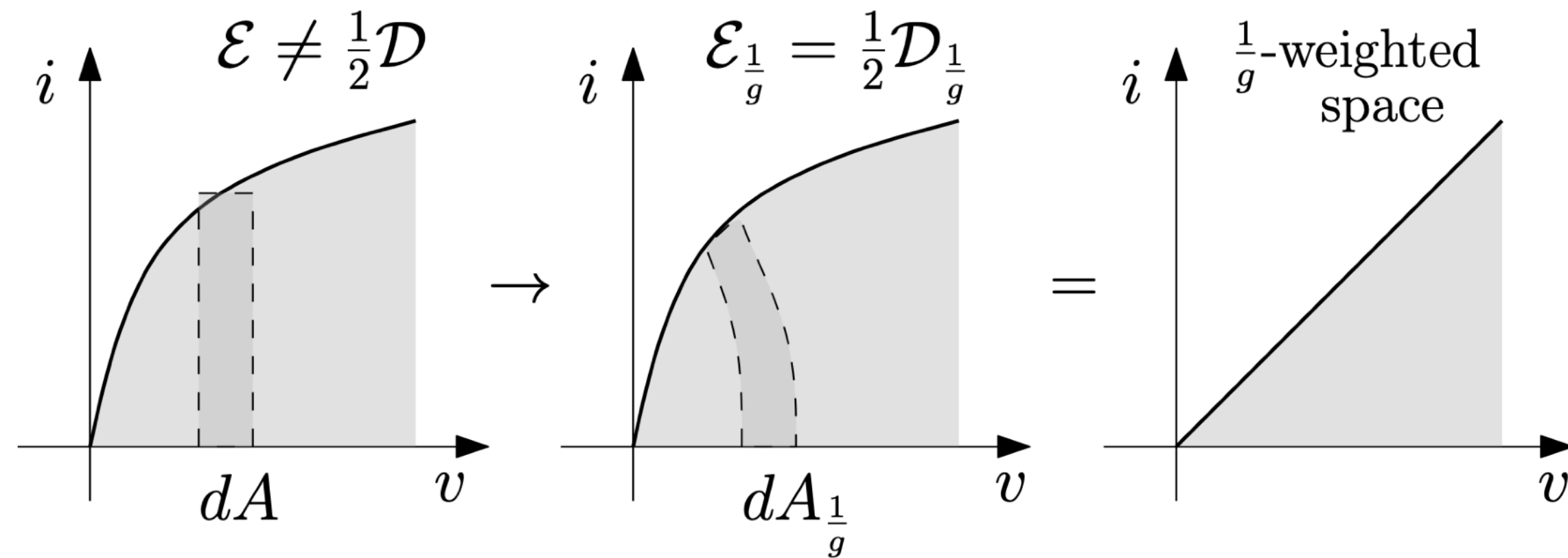

$$\mathcal{E}(\bar{v}) := \int_0^{\bar{v}} \langle i, dv \rangle = \int_0^{\bar{v}} g(v)v dv \neq \frac{1}{2} \langle \bar{v}, \bar{v} \rangle_g$$



$1/g$ - dissipated energy

$1/g$ co-content

$$\mathcal{D}_{\frac{1}{g}}(v) := \langle i, v \rangle_{\frac{1}{g}} = v^2 = \langle v, v \rangle$$

$$\mathcal{E}_{\frac{1}{g}}(\bar{v}) := \int_0^{\bar{v}} \langle i, dv \rangle_{\frac{1}{g}} = \int_0^{\bar{v}} v dv = \frac{1}{2} \bar{v}^2 = \frac{1}{2} \langle \bar{v}, \bar{v} \rangle$$

Nonlinear resistor (on the Riemannian manifold with metric 1/g)

$$i = g(v)v$$

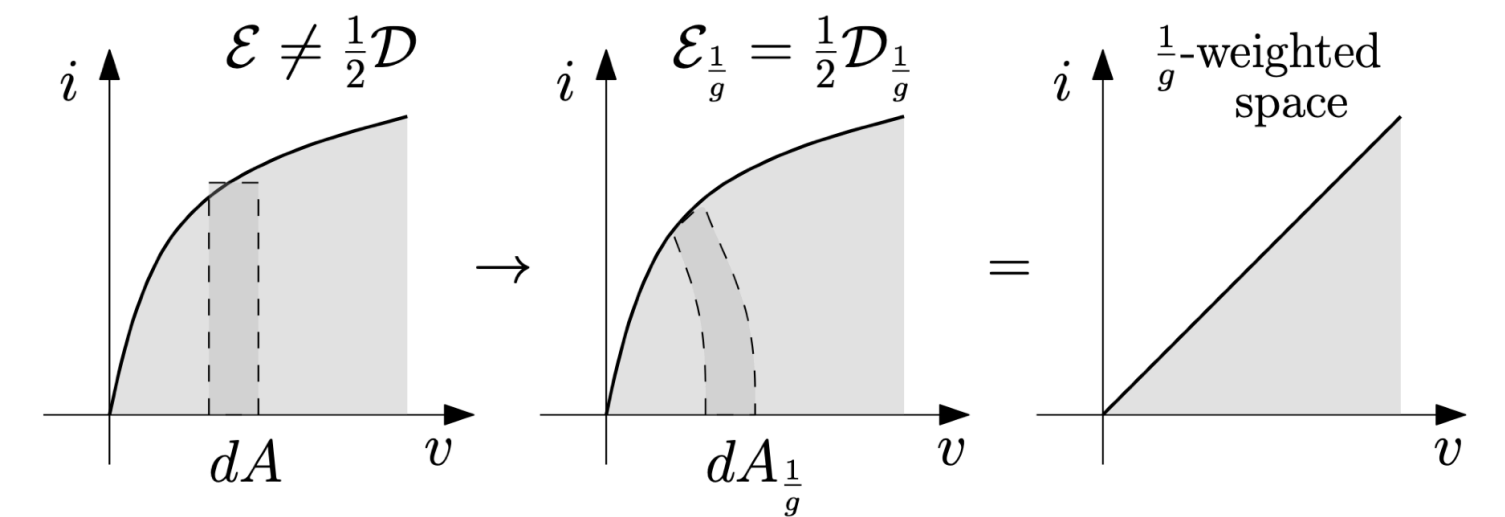

1/g - dissipated energy

$$\mathcal{D}_{\frac{1}{g}}(v) := \langle i, v \rangle_{\frac{1}{g}} = v^2 = \langle v, v \rangle$$

1/g co-content

$$\mathcal{E}_{\frac{1}{g}}(\bar{v}) := \int_0^{\bar{v}} \langle i, dv \rangle_{\frac{1}{g}} = \int_0^{\bar{v}} v dv = \frac{1}{2} \bar{v}^2 = \frac{1}{2} \langle \bar{v}, \bar{v} \rangle$$

The 1/g co-content determines the resistive relationship

$$\left\langle \text{grad}_{\frac{1}{g}} \mathcal{E}_{\frac{1}{g}}(v), v \right\rangle_{\frac{1}{g}} = D_v \mathcal{E}_{\frac{1}{g}}(v) = v^2$$

$$i = \text{grad}_{\frac{1}{g}} \mathcal{E}_{\frac{1}{g}}(v) = g(v)v$$

Memristor



$$\mathbf{i}(t) = \mathbf{g}(\mathbf{v})(t) \mathbf{v}(t),$$

Inner products

$$\langle \mathbf{v}_1, \mathbf{v}_2 \rangle = \int_{-\infty}^T \mathbf{v}_1(t) \mathbf{v}_2(t) dt \quad \langle \mathbf{v}_1, \mathbf{v}_2 \rangle_{\frac{1}{\mathbf{g}}} = \int_{-\infty}^T \frac{\mathbf{v}_1(t) \mathbf{v}_2(t)}{\mathbf{g}(\mathbf{v})(t)} dt$$

1/g - dissipated energy

$$\mathcal{D}_{\frac{1}{\mathbf{g}}} = \langle \mathbf{v}, \mathbf{v} \rangle$$

1/g co-content

$$\mathcal{E}_{\frac{1}{\mathbf{g}}} = \frac{1}{2} \langle \mathbf{v}, \mathbf{v} \rangle$$

The 1/g co-content determines the resistive relationship

$$\left\langle \mathbf{grad}_{\frac{1}{\mathbf{g}}} \mathcal{E}_{\frac{1}{\mathbf{g}}}(\mathbf{v}), \mathbf{v} \right\rangle_{\frac{1}{\mathbf{g}}} = \mathbf{D}_{\mathbf{v}} \mathcal{E}_{\frac{1}{\mathbf{g}}}(\mathbf{v}) = \langle \mathbf{v}, \mathbf{v} \rangle,$$

$$\mathbf{i} = \mathbf{grad}_{\frac{1}{\mathbf{g}}} \mathcal{E}_{\frac{1}{\mathbf{g}}}(\mathbf{v}) = \mathbf{g}(\mathbf{v})(\cdot) \mathbf{v}(\cdot)$$

Linear resistor

$$i(t) = gv(t)$$

$$\mathcal{E}_{\frac{1}{g}}(\bar{v}) := \frac{1}{2} \langle \bar{v}, \bar{v} \rangle$$

$$i = \text{grad}_{\frac{1}{g}} \mathcal{E}_{\frac{1}{g}}(v)$$

Memristor

$$\mathbf{i}(t) = \mathbf{g}(\mathbf{v})(t) \mathbf{v}(t),$$

$$\mathcal{E}_{\frac{1}{\mathbf{g}}} = \frac{1}{2} \langle \mathbf{v}, \mathbf{v} \rangle$$

$$\mathbf{i} = \text{grad}_{\frac{1}{\mathbf{g}}} \mathcal{E}_{\frac{1}{\mathbf{g}}}(\mathbf{v})$$

Gradient modeling of memristive circuits

Part 1: Motivation

Part 2: Gradient resistive and memristive elements

Part 3: linear RC and mem-RC circuits

Part 4: On memcapacitance and excitable robotics...

Linear RC

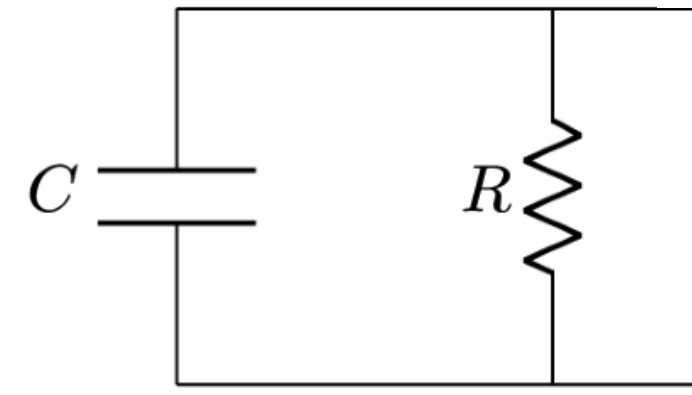

Dynamics

$$C\dot{v} = -gv + i = -\text{grad } \mathcal{E}(v) + \text{grad } \langle v, i \rangle$$

Potential (constant currents)

$$\mathcal{P}(v) = \mathcal{E}(v) - \langle v, i \rangle$$

Convergence

$$\dot{\mathcal{P}}(v) = D_{\dot{v}}\mathcal{P}(v) = \langle \text{grad } \mathcal{P}(v), \dot{v} \rangle = -\gamma \text{grad } \mathcal{P}(v)^2$$

Linear RC

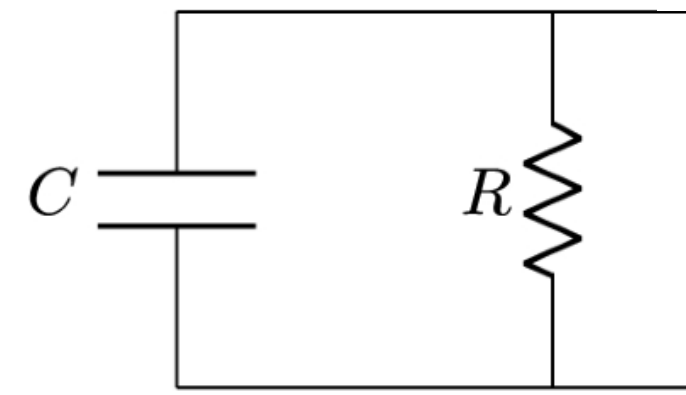

Dynamics

$$C\dot{v} = -gv + i = -\text{grad } \mathcal{E}(v) + \text{grad } \langle v, i \rangle$$

Potential (constant currents)

$$\mathcal{P}(v) = \mathcal{E}(v) - \langle v, i \rangle$$

Convergence

$$\dot{\mathcal{P}}(v) = D_v \mathcal{P}(v) = \langle \text{grad } \mathcal{P}(v), \dot{v} \rangle = -\gamma \text{grad } \mathcal{P}(v)^2$$

mem-RC

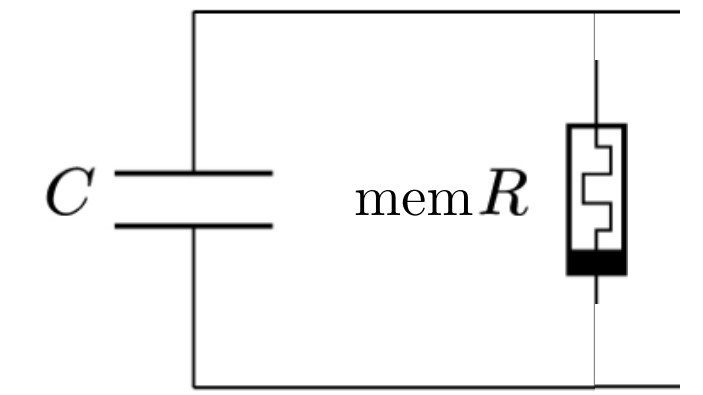

$$\mathcal{E}_{\frac{1}{g}} = \frac{1}{2} \langle \mathbf{v}, \mathbf{v} \rangle$$

Dynamics

$$C\dot{v} = -\text{grad}_{\frac{1}{g}} \mathcal{E}_{\frac{1}{g}}(\mathbf{v}) + \text{grad } \langle \mathbf{i}, \mathbf{v} \rangle$$

Energy dissipation

$$S_C(\mathbf{v}(t)) = \frac{1}{2} C \mathbf{v}(t)^2.$$

$$S_C(\mathbf{v}(T)) - S_C(\mathbf{v}(-\infty)) = \langle \mathbf{v}, C\dot{\mathbf{v}} \rangle$$

$$= \left\langle \mathbf{v}, -\text{grad}_{\frac{1}{g}} \mathcal{E}_{\frac{1}{g}}(\mathbf{v}) + \mathbf{i} \right\rangle$$

$$\leq \langle \mathbf{i}, \mathbf{v} \rangle$$

$$\text{for closed trajectories } \left\langle \mathbf{v}, -\text{grad}_{\frac{1}{g}} \mathcal{E}_{\frac{1}{g}}(\mathbf{v}) + \mathbf{i} \right\rangle = 0.$$

Hodgkin-Huxley gradient memcircuit

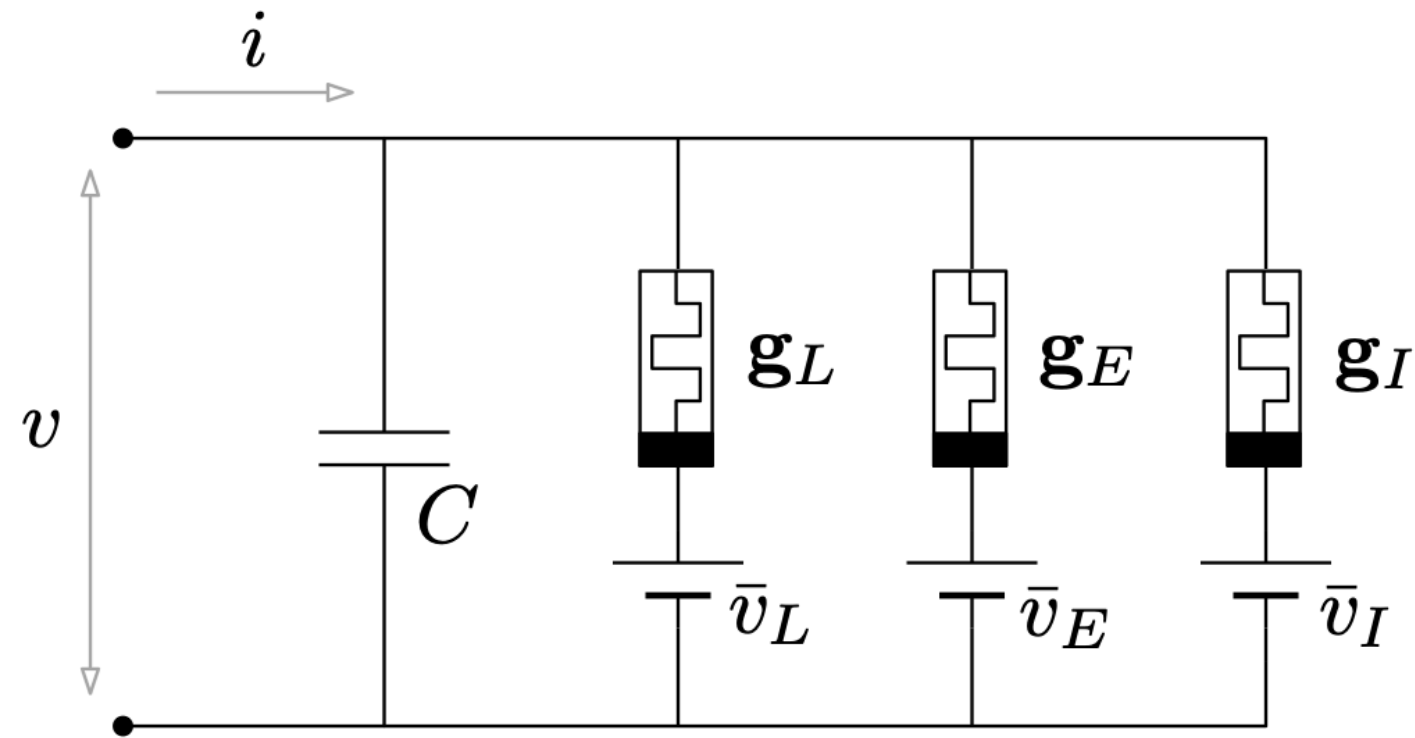

$$C\dot{v} = -i_L - i_E - i_I + i$$

$$i_L = g_L(\mathbf{v} - \bar{\mathbf{v}}_L)(v - \bar{v}_L)$$

$$i_E = g_E(\mathbf{v} - \bar{\mathbf{v}}_E)(v - \bar{v}_E)$$

$$i_I = g_I(\mathbf{v} - \bar{\mathbf{v}}_I)(v - \bar{v}_I)$$

Gradient view

$$\mathcal{E}_{\frac{1}{g_L}} = \mathcal{E}_{\frac{1}{g_E}} = \mathcal{E}_{\frac{1}{g_I}} = \frac{1}{2} \langle \mathbf{v}, \mathbf{v} \rangle$$



$$C\dot{v} = -\text{grad}_{\frac{1}{g_L}} \mathcal{E}_{\frac{1}{g_L}}(\mathbf{v} - \bar{\mathbf{v}}_L) - \text{grad}_{\frac{1}{g_E}} \mathcal{E}_{\frac{1}{g_E}}(\mathbf{v} - \bar{\mathbf{v}}_E) - \text{grad}_{\frac{1}{g_I}} \mathcal{E}_{\frac{1}{g_I}}(\mathbf{v} - \bar{\mathbf{v}}_I) + \text{grad} \langle \mathbf{v}, \mathbf{i} \rangle.$$

Take now $\mathbb{1}^\top = [1, 1, 1]$ and define

$$\bar{\mathbf{V}}^\top = [\bar{v}_L \quad \bar{v}_E \quad \bar{v}_I],$$

$$\frac{1}{\mathbf{G}} = \text{diag} \left(\frac{1}{g_L}, \frac{1}{g_E}, \frac{1}{g_I} \right),$$

$$\mathcal{E}_{\frac{1}{\mathbf{G}}} = \text{diag} \left(\mathcal{E}_{\frac{1}{g_L}}, \mathcal{E}_{\frac{1}{g_E}}, \mathcal{E}_{\frac{1}{g_I}} \right).$$

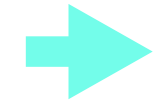

$$C\dot{v} = \mathbb{1}^\top \text{grad}_{\frac{1}{\mathbf{G}}} \mathcal{E}_{\frac{1}{\mathbf{G}}}(\mathbb{1}\mathbf{v} - \bar{\mathbf{V}}) + \text{grad} \langle \mathbf{v}, \mathbf{i} \rangle$$

Network view

Hodgkin-Huxley gradient memcircuit

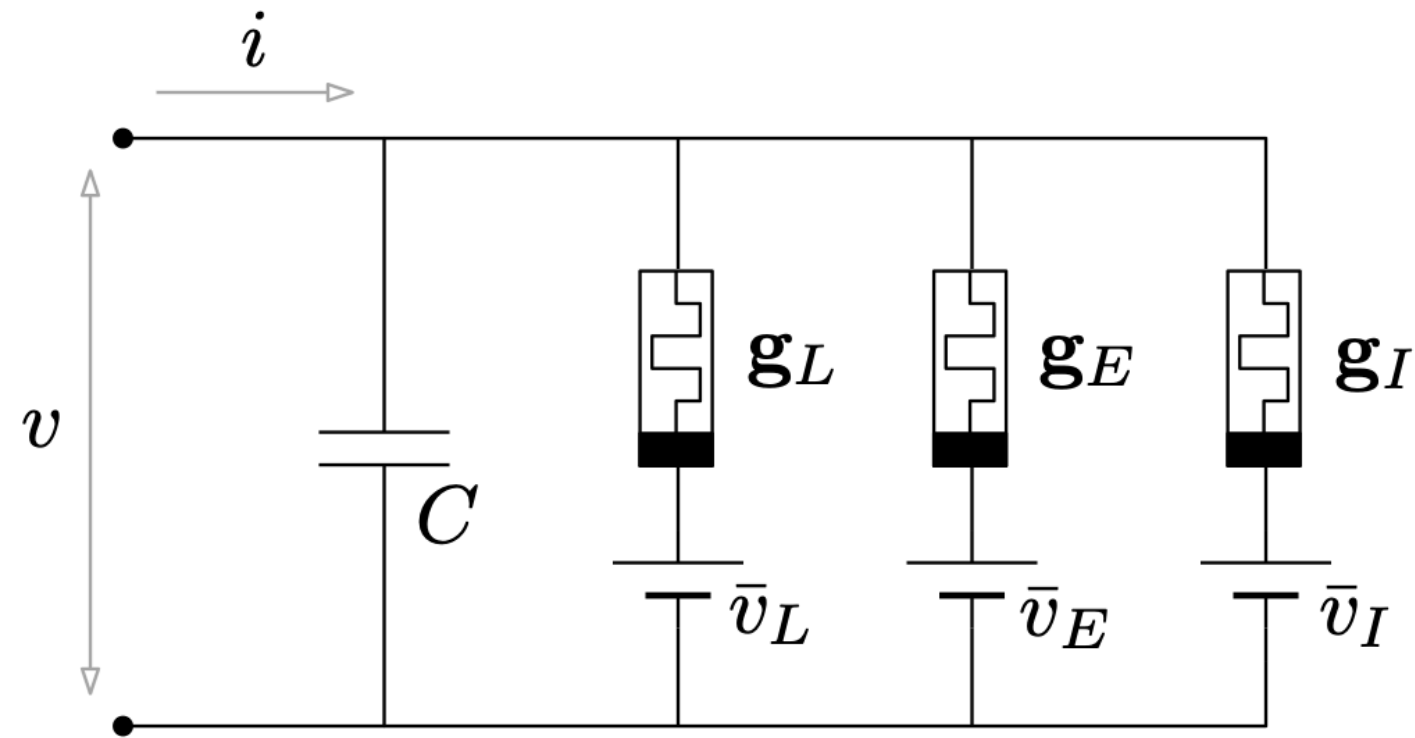

$$C\dot{v} = -i_L - i_E - i_I + i$$

$$i_L = g_L(\mathbf{v} - \bar{\mathbf{v}}_L)(v - \bar{v}_L)$$

$$i_E = g_E(\mathbf{v} - \bar{\mathbf{v}}_E)(v - \bar{v}_E)$$

$$i_I = g_I(\mathbf{v} - \bar{\mathbf{v}}_I)(v - \bar{v}_I)$$

$$\mathcal{E}_{\frac{1}{g_L}} = \mathcal{E}_{\frac{1}{g_E}} = \mathcal{E}_{\frac{1}{g_I}} = \frac{1}{2} \langle \mathbf{v}, \mathbf{v} \rangle$$

Gradient view

Take now $\mathbb{1}^\top = [1, 1, 1]$ and define

$$\bar{\mathbf{V}}^\top = [\bar{v}_L \quad \bar{v}_E \quad \bar{v}_I],$$

$$\frac{1}{\mathbf{G}} = \text{diag} \left(\frac{1}{g_L}, \frac{1}{g_E}, \frac{1}{g_I} \right),$$

$$\mathcal{E}_{\frac{1}{\mathbf{G}}} = \text{diag} \left(\mathcal{E}_{\frac{1}{g_L}}, \mathcal{E}_{\frac{1}{g_E}}, \mathcal{E}_{\frac{1}{g_I}} \right).$$

Network view

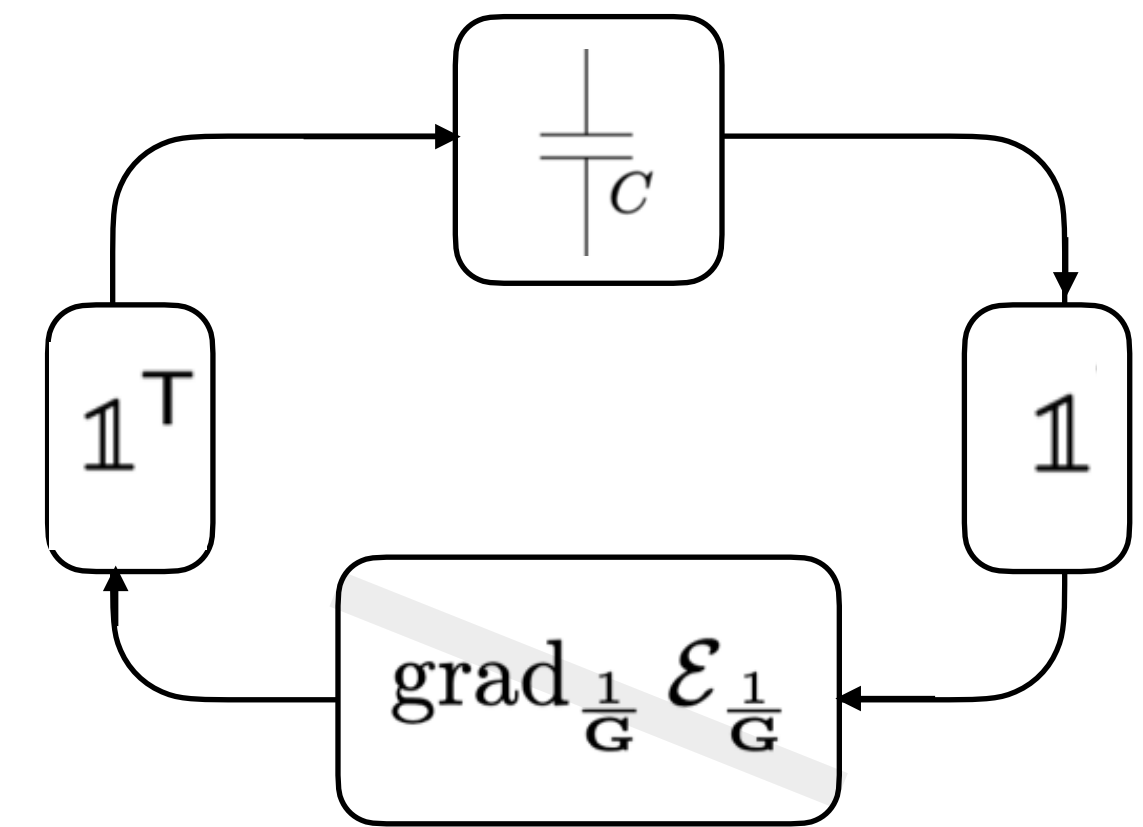

$$C\dot{v} = \mathbb{1}^\top \text{grad}_{\frac{1}{\mathbf{G}}} \mathcal{E}_{\frac{1}{\mathbf{G}}} (\mathbb{1}\mathbf{v} - \bar{\mathbf{V}}) + \text{grad} \langle \mathbf{v}, \mathbf{i} \rangle$$

Hodgkin-Huxley gradient memcircuit

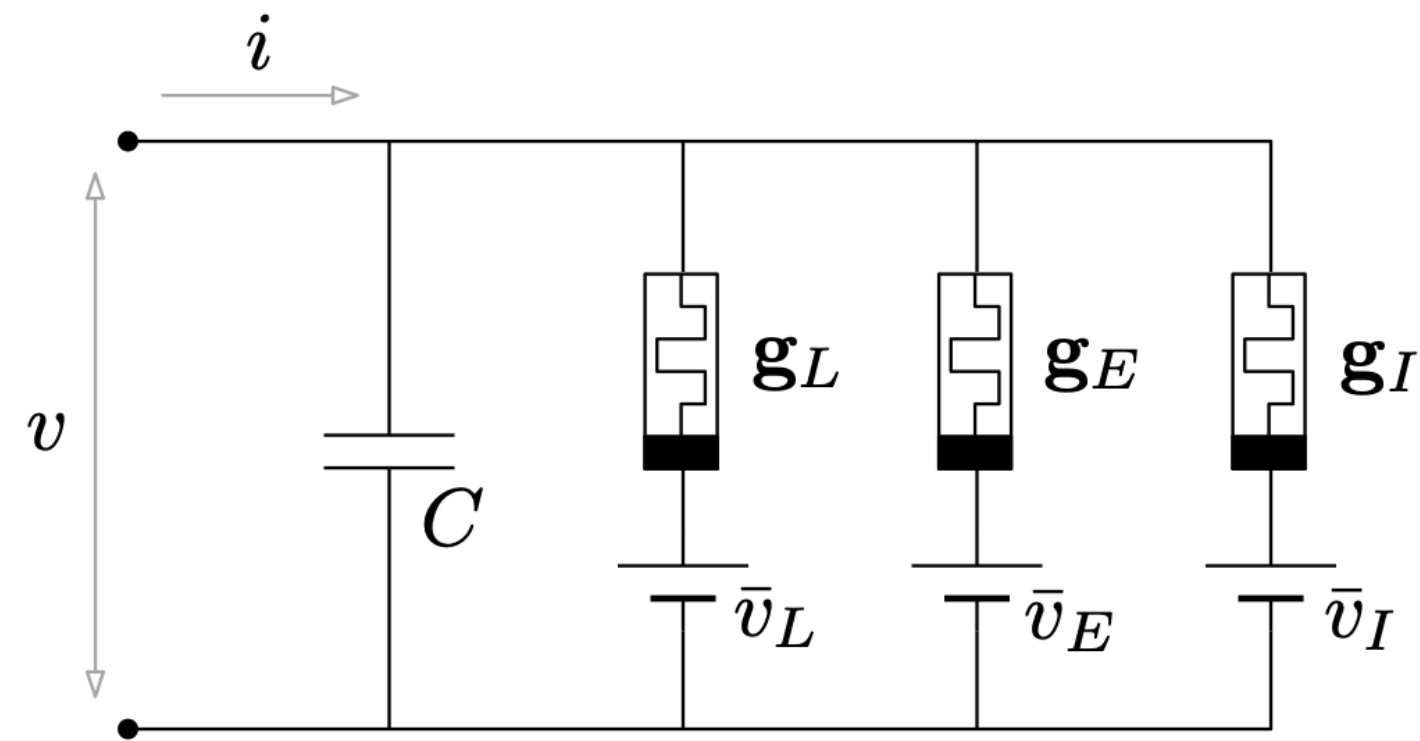

$$C\dot{v} = -i_L - i_E - i_I + i$$

$$i_L = g_L(\mathbf{v} - \bar{\mathbf{v}}_L)(v - \bar{v}_L)$$

$$i_E = g_E(\mathbf{v} - \bar{\mathbf{v}}_E)(v - \bar{v}_E)$$

$$i_I = g_I(\mathbf{v} - \bar{\mathbf{v}}_I)(v - \bar{v}_I)$$

What representation for conductances? (why ODEs?)

Compute: zeros instead of integration steps

two-step iteration - (i) given v update G , (ii) given G update V

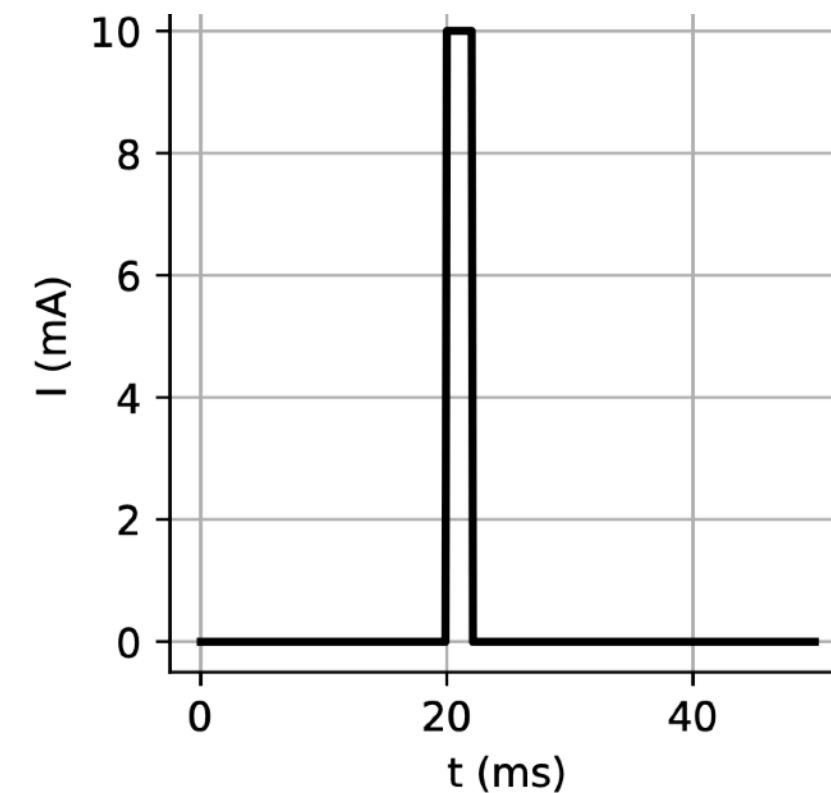
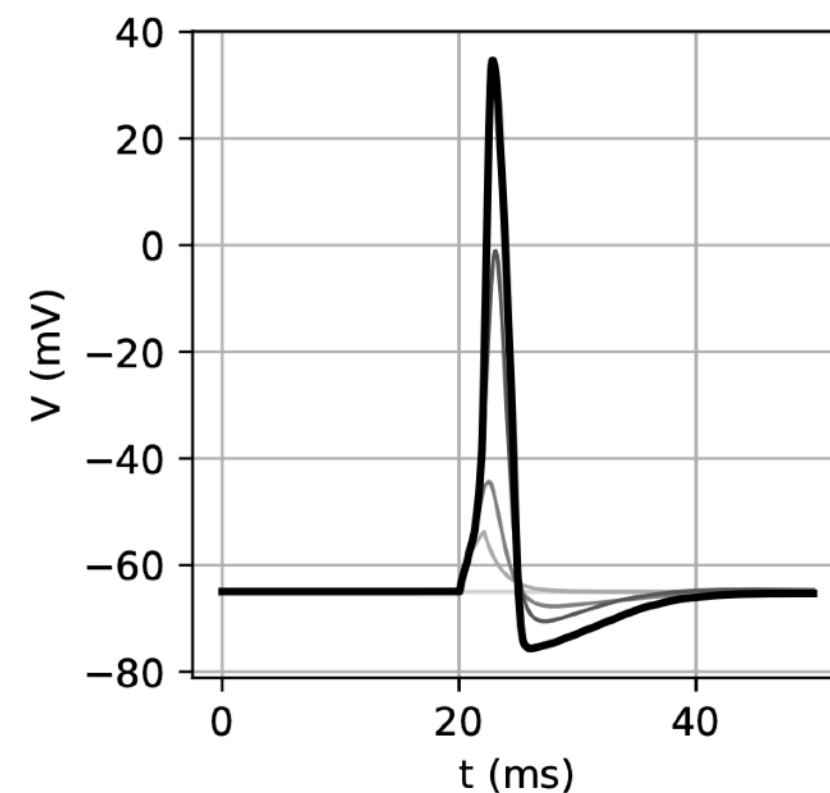

$$C\dot{v} = \mathbf{1}^T \text{grad}_{\frac{1}{\mathbf{G}}} \mathcal{E}_{\frac{1}{\mathbf{G}}} (\mathbf{1}\mathbf{v} - \bar{\mathbf{V}}) + \text{grad} \langle \mathbf{v}, \mathbf{i} \rangle$$

Gradient modeling of memristive circuits

Part 1: Motivation

Part 2: Gradient resistive and memristive elements

Part 3: linear RC and mem-RC circuits

Part 4: On memcapacitance and excitable robotics...

Mem-elements (a proposal)

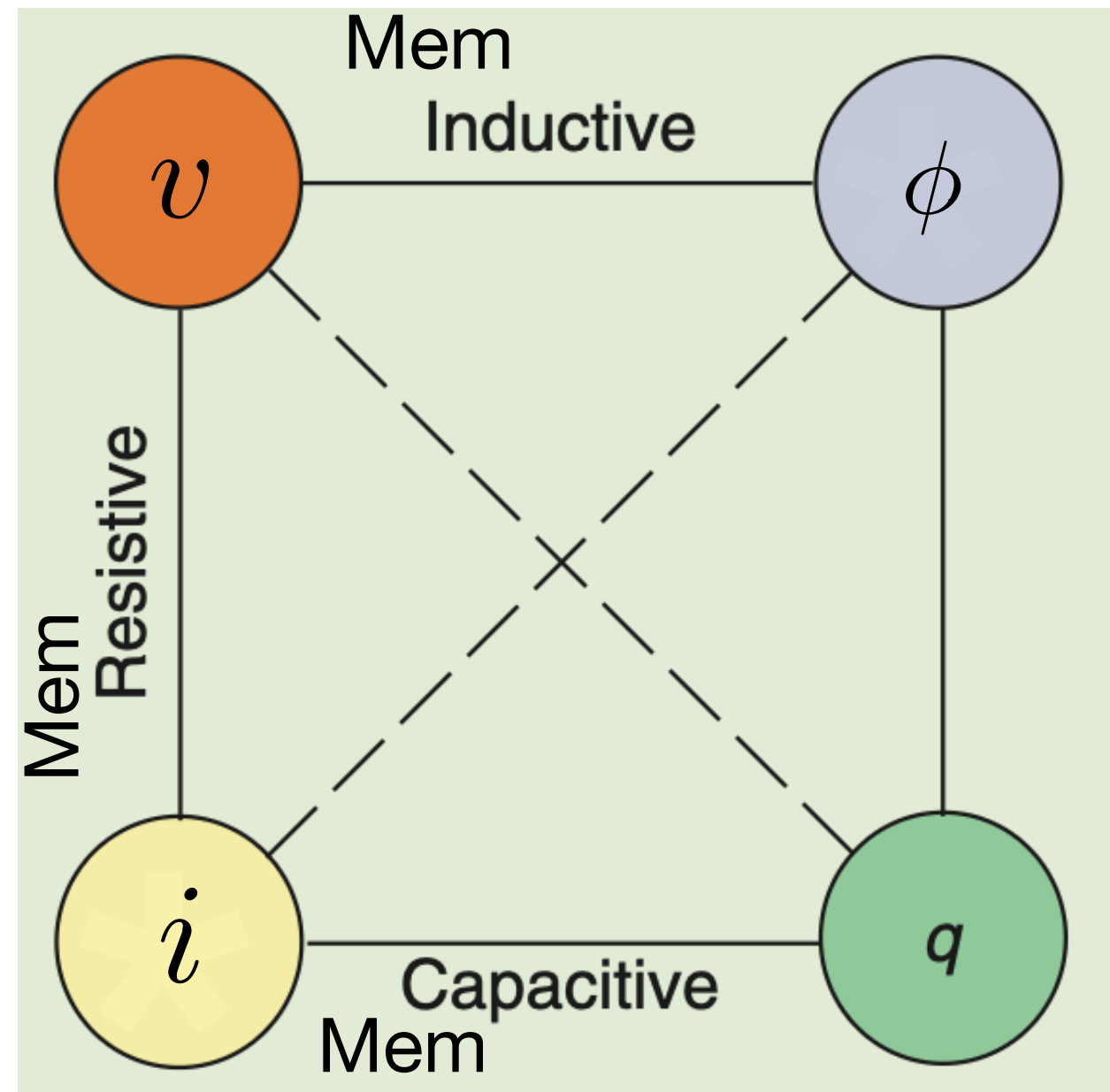

Memcapacitor

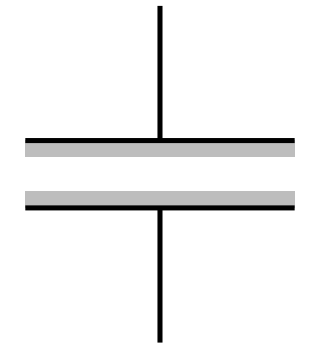

$$q = c(\mathbf{v})v$$

$$\dot{q} = i$$

$$i = \dot{c}(\mathbf{v})v + c(\mathbf{v})\dot{v}$$

$$c(\mathbf{v})\dot{v} = -\dot{c}(\mathbf{v})v + i.$$

1/g co-content

$$\mathcal{E}_{\frac{1}{c}}^*(\bar{\mathbf{v}}) := \int_0^{\bar{\mathbf{v}}} \langle \mathbf{q}, d\mathbf{v} \rangle_{\frac{1}{c}} = \frac{1}{2} \langle \bar{\mathbf{v}}, \bar{\mathbf{v}} \rangle$$

The 1/g co-content determines the resistive relationship

$$\mathbf{q} = \text{grad}_{\frac{1}{c}} \mathcal{E}_{\frac{1}{c}}^*(\mathbf{v})$$

Passivity?

Cyclo-passivity of the nonlinear capacitor

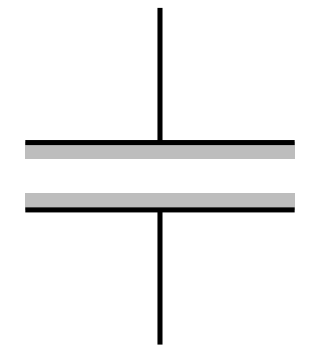

$$q = c(v)v$$

$$\dot{q} = i$$

$$i = c(v)\dot{v} + \dot{c}(v)v$$

$$S(v) := \int_0^v \langle c(u)u, du \rangle$$

$$\dot{S} = \partial_v \int_0^v \langle c(\bar{v})\bar{v}, d\bar{v} \rangle \dot{v} = c(v)v\dot{v} = vi - \dot{c}(v)v^2$$

$$0 = S(v(T)) - S(v(-\infty)) = \int_{-\infty}^T vi \, dt + H(v(T)) - H(v(-\infty)) = \int_{-\infty}^T vi \, dt$$

$$H(v) = \int_0^v (\partial_u c(u)) u^2 du.$$

Lagrangian modeling of the nonlinear capacitor

$$L = \int_0^v \langle c(\bar{v})\bar{v}, d\bar{v} \rangle \quad i = \frac{d}{dt} \partial_v L = \frac{d}{dt} (c(v)v) = c(v)\dot{v} + \dot{c}(v)v = i$$

Cyclo-passive

$$L = \frac{1}{2} c(\phi) v^2$$

$$\phi = \int v$$

$$\begin{aligned} i &= \frac{d}{dt} \partial_v L - \partial_\phi L \\ &= \frac{d}{dt} (c(\phi)v) - \frac{1}{2} \partial_\phi c(\phi) v^2 \\ &= \dot{c}(\phi)v + c(\phi)\dot{v} - \frac{1}{2} \partial_\phi c(\phi) v^2 \\ &= c(\phi)\dot{v} + \frac{1}{2} \partial_\phi c(\phi) v^2 \\ &= c(\phi)\dot{v} + \frac{1}{2} \dot{c}(\phi) v. \end{aligned}$$

Passive

$$\begin{aligned} \frac{d}{dt} \frac{1}{2} c(\phi) v^2 &= \frac{1}{2} \dot{c}(\phi) v^2 + c(\phi) v \dot{v} \\ &= \frac{1}{2} \dot{c}(\phi) v^2 - \frac{1}{2} \dot{c}(\phi) v^2 + i v \\ &= i v. \end{aligned}$$

Mechanical mem-circuit (a proposal)

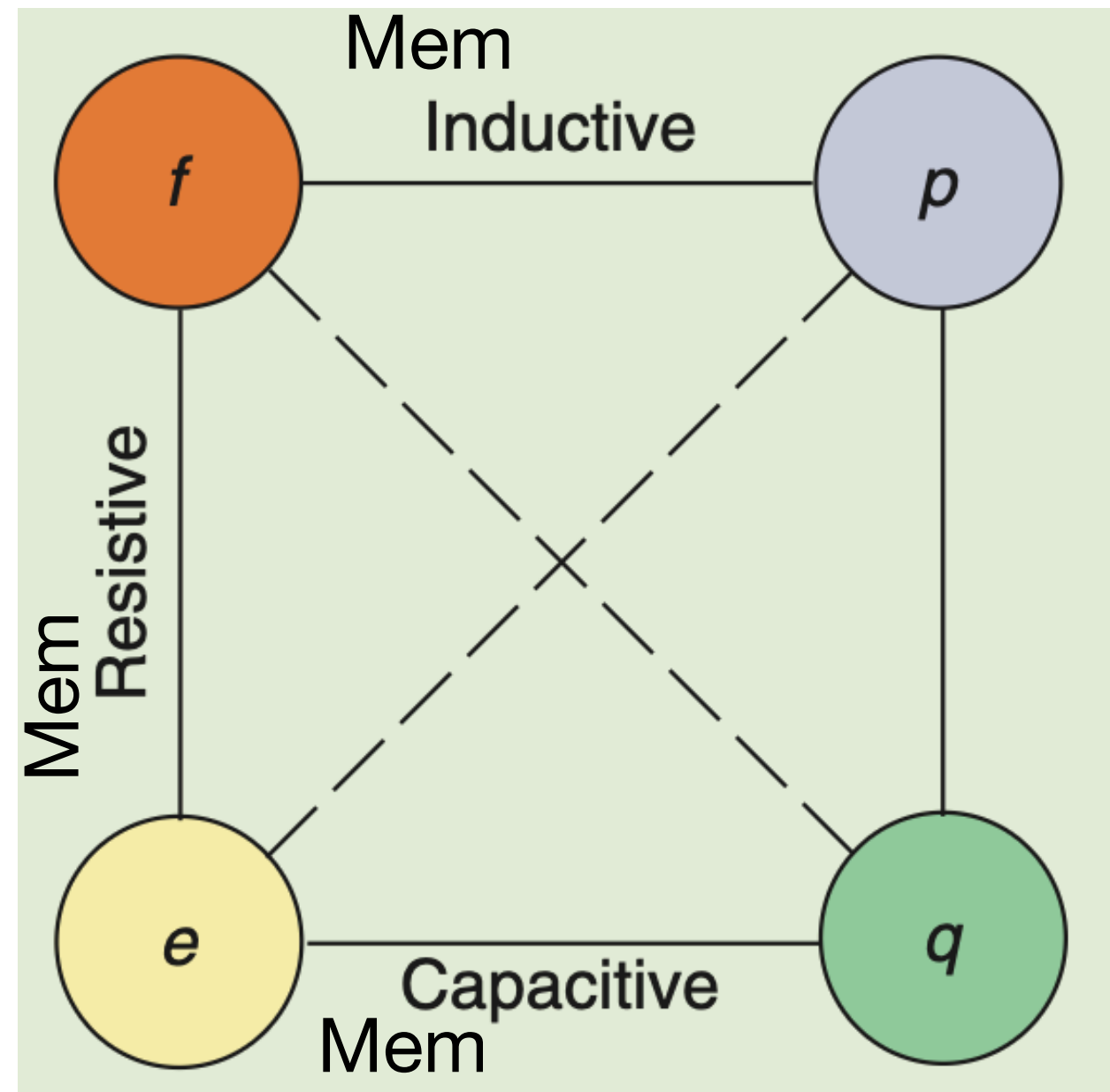

A mechanical spike

Y. Zhang and T. Huo

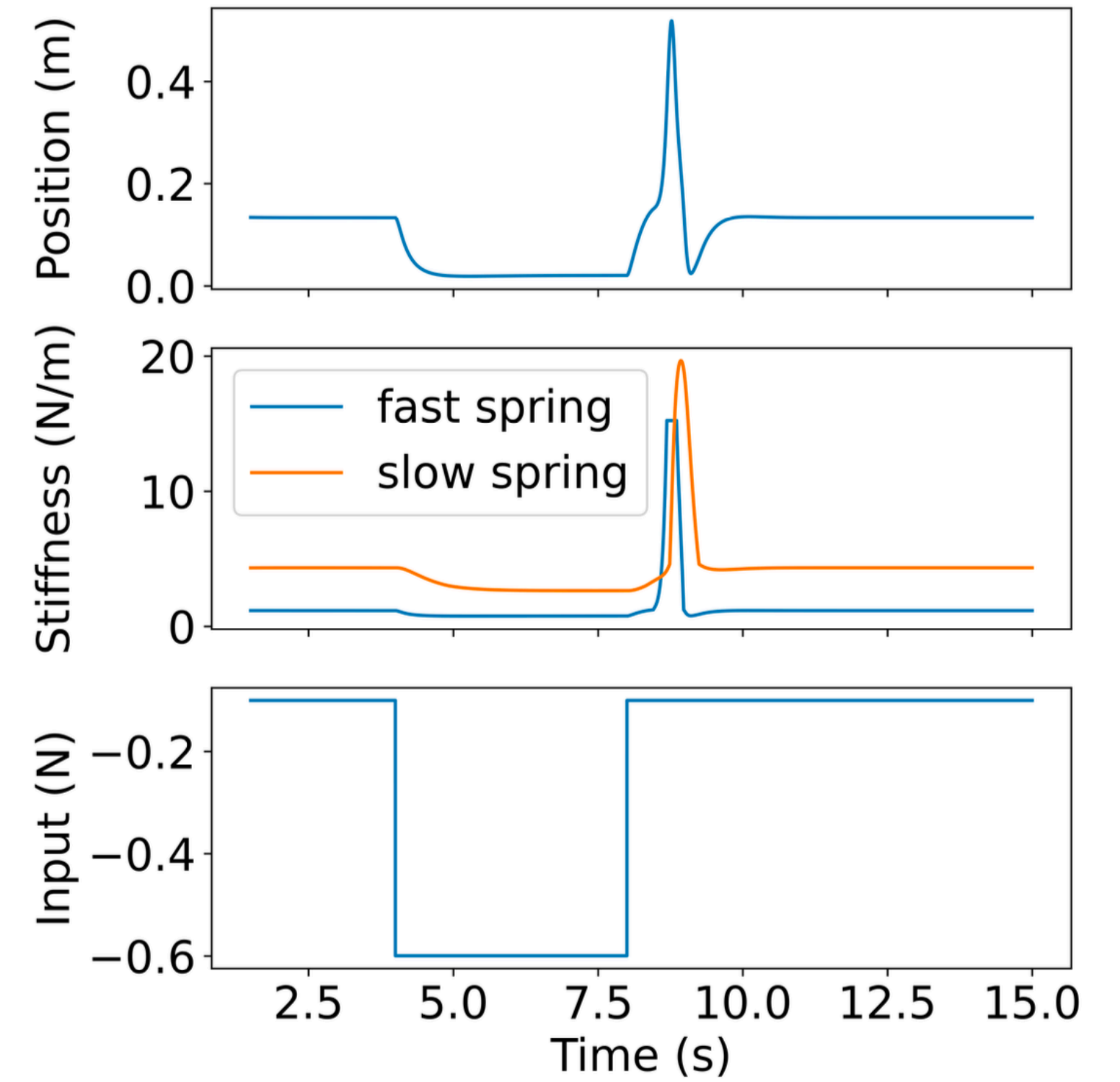
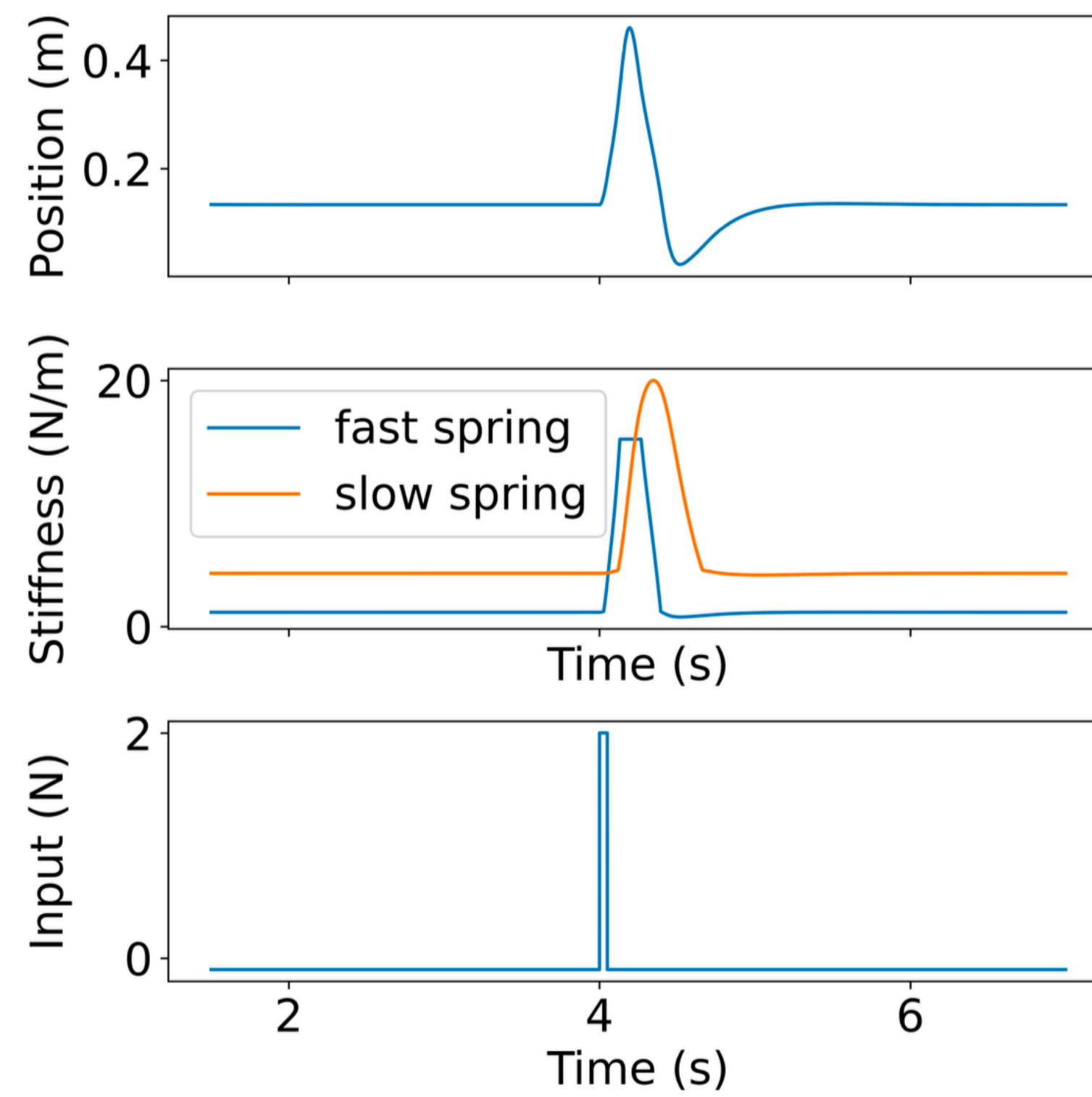

A mechanical spike

Y. Zhang and T. Huo

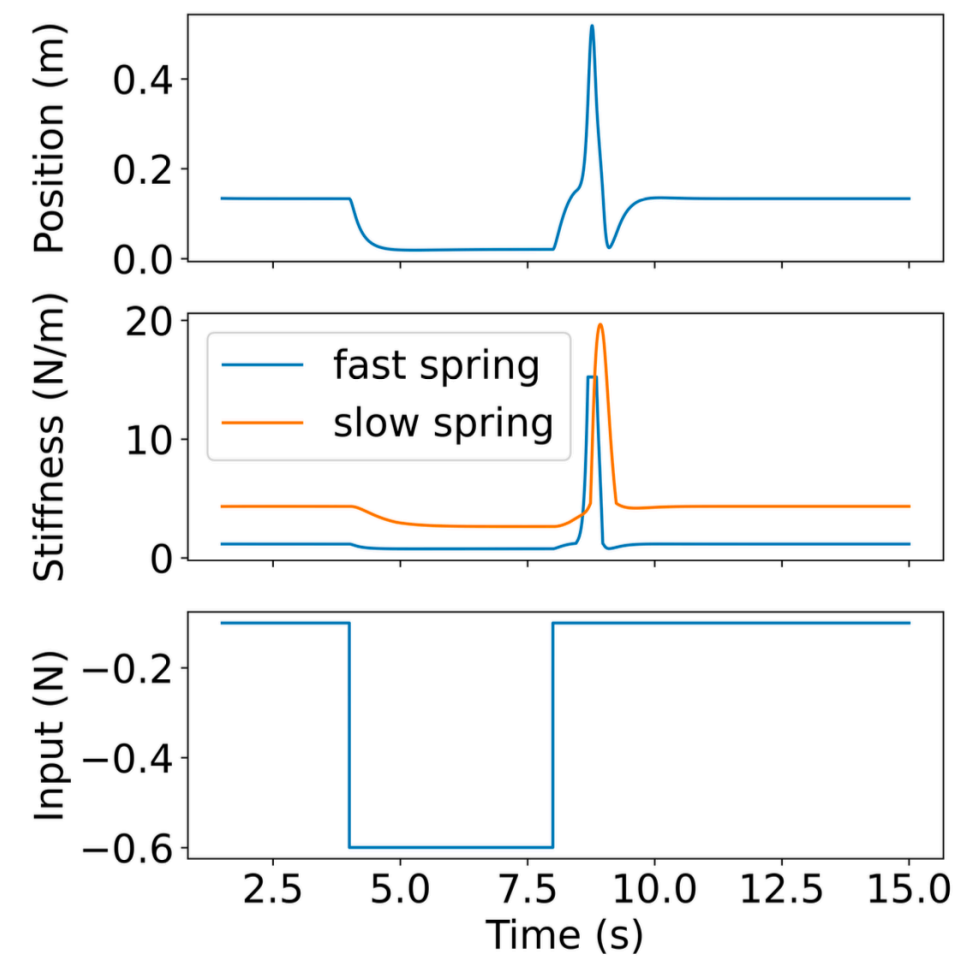
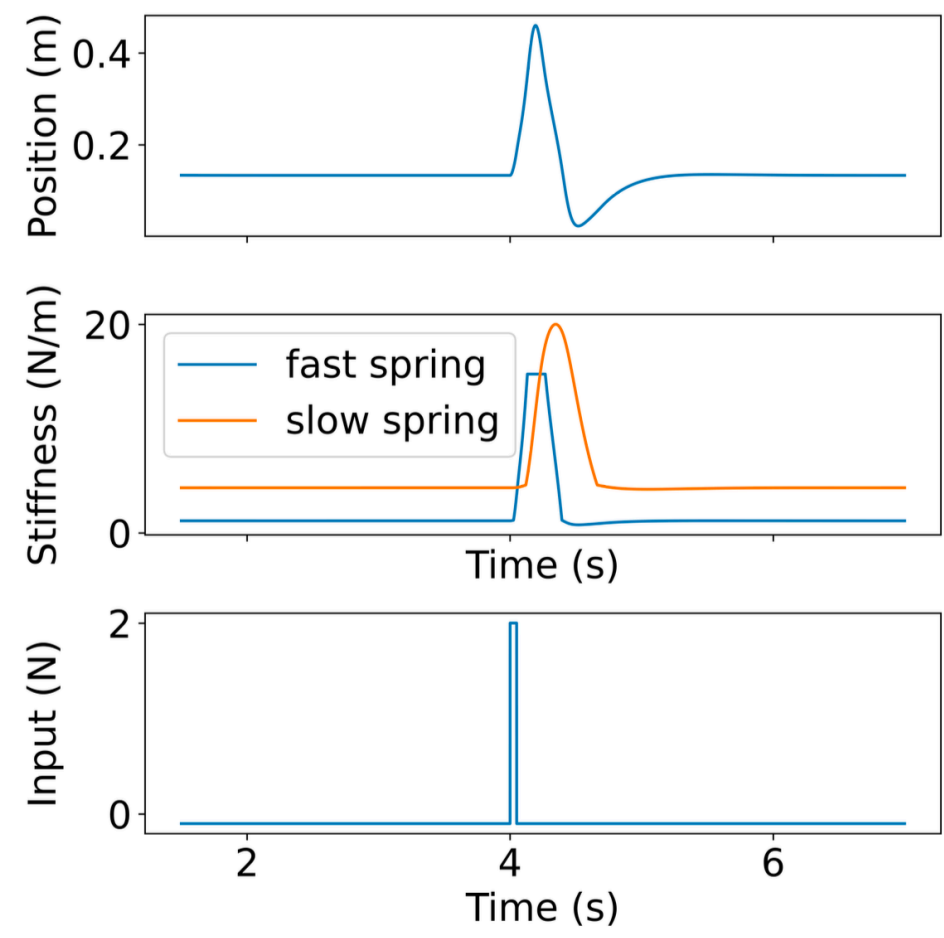

Thank you!

...and thanks to R. Sepulchre, Y. Zhang and T. Huo!

F. Forni, R. Sepulchre, **Gradient modelling of memristive systems**,
IEEE Conference on Decision and Control, 2025. [arXiv](#)

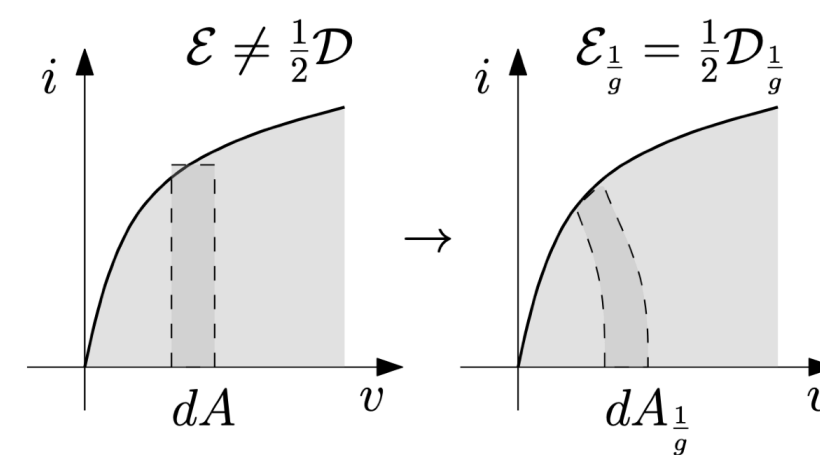

$$\mathbf{i}(t) = \mathbf{g}(\mathbf{v})(t) \mathbf{v}(t) = \text{grad}_{\frac{1}{\mathbf{g}}} \mathcal{E}_{\frac{1}{\mathbf{g}}}(\mathbf{v})$$



A.L. Hodgkin, A.F. Huxley, **A quantitative description of membrane current and its application to conduction and excitation in nerve**. Bulletin of Mathematical Biology Vol. 52, No. 1/2, 1990

L.O. Chua, S.M.Kang, **Memristive devices and systems**. Proceedings of the IEEE, Vol. 64, No. 2 1976

D. Jeltsema, J. Scherpen, **Multidomain modeling of nonlinear network and systems**, IEEE Control Systems Magazine, Vol. 29, No. 4, 2009